

PENCIL AND PAD

PART 2.

TECHNICAL DRAWING

CONTENTS

	<u>Page</u>
Spatial Reasoning	36
Orthographic Projection - Advanced	37 - 39
Dimensioning	40 - 42
Orthographic Projection & Dimensioning - Assessment	43
Dimensioning	44
Enlargement	45 - 46
Development	47 - 56
Oblique Projection - Advanced	57
Isometric Projection - Advanced	58
Oblique Projection - Advanced	59
Orthographic/Oblique Projection - Assessment	60
Spatial Reasoning	61
Rendering (Shading)	62 - 63
Orthographic Projection - Advanced	64
Oblique Projection - Advanced	65
Orthographic Projection - Advanced	66
Isometric Projection - Advanced	67 - 68
Oblique Projection - Advanced	69
Circles - Isometric	70 - 73
Circles - Oblique	74 - 75





Published and
Distributed by :

Hawker Brownlow Education
235 BAY ROAD
CHELTENHAM, MELBOURNE VICTORIA 3192
TELEPHONE 555 1344

Copyright 1976 :

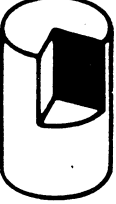
G. W. Hoare

SELECT THE ONE SET OF ORTHOGRAPHIC VIEWS WHICH SUIT THE ISOMETRIC DRAWING ON LEFT.

1.     

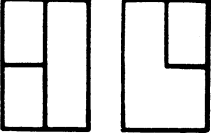
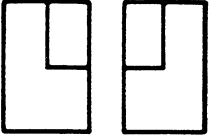
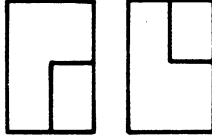
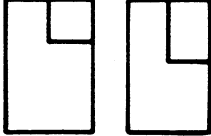
I  II  III  IV 

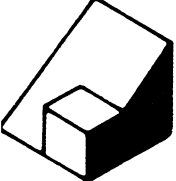
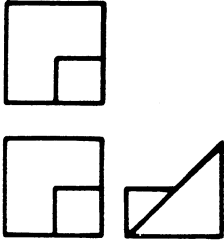
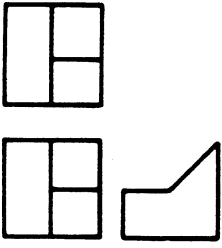
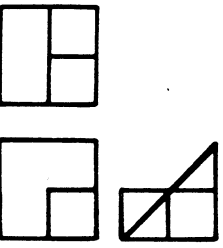
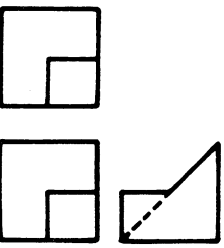
2.  I  II  III  IV 

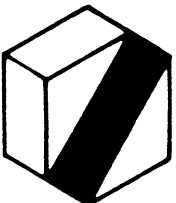
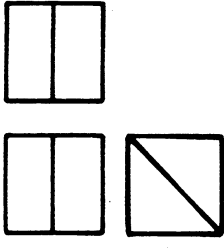
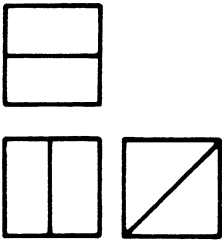
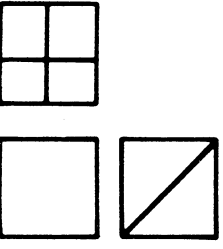
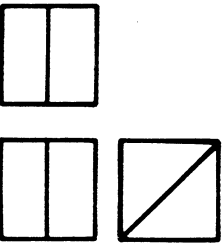
3.  I  II  III  IV 

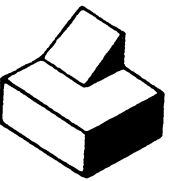
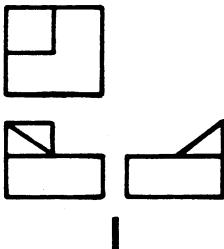
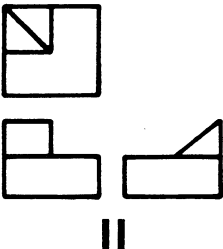
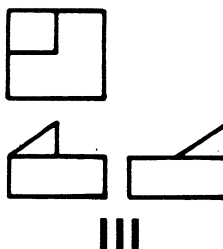
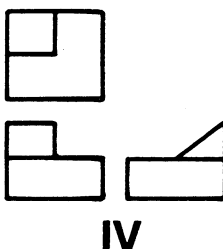
4.  I  II  III  IV 

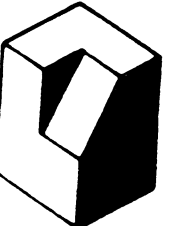
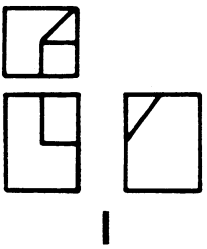
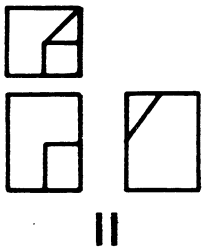
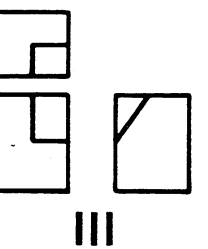
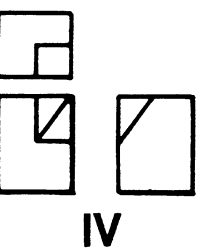
5.  I  II  III  IV 

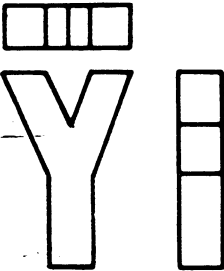
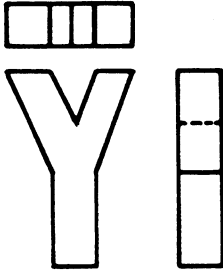
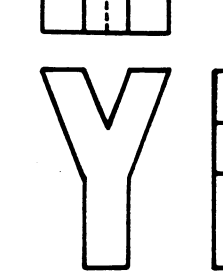
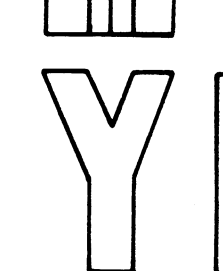
6.  I  II  III  IV 

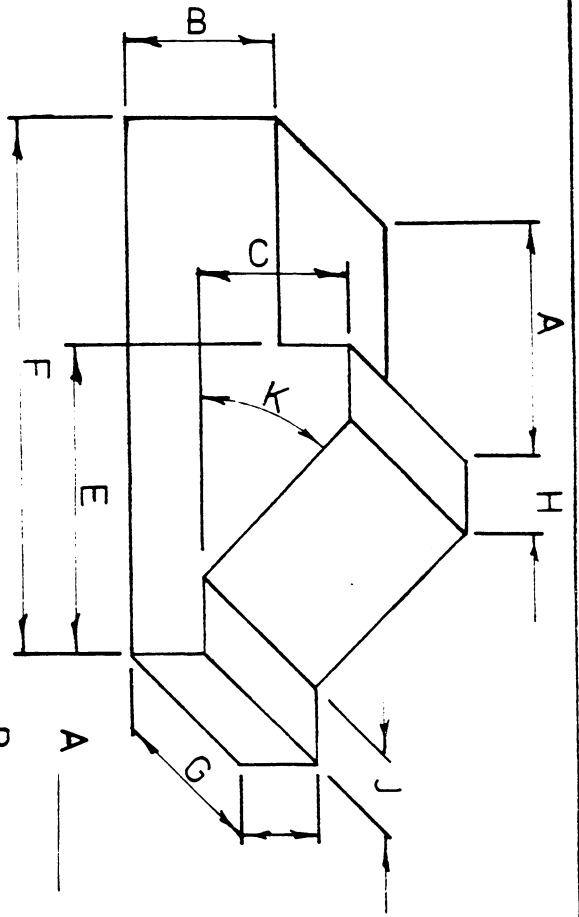
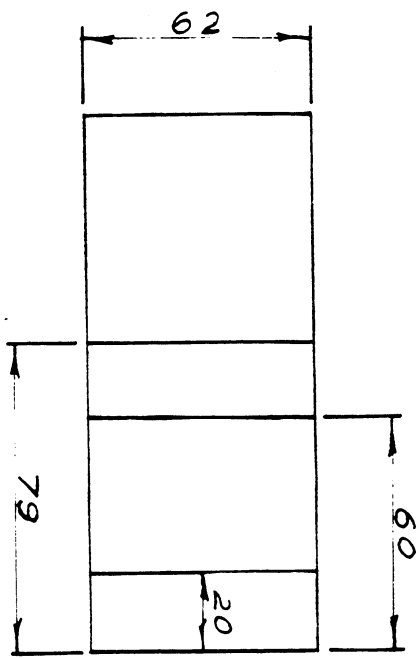
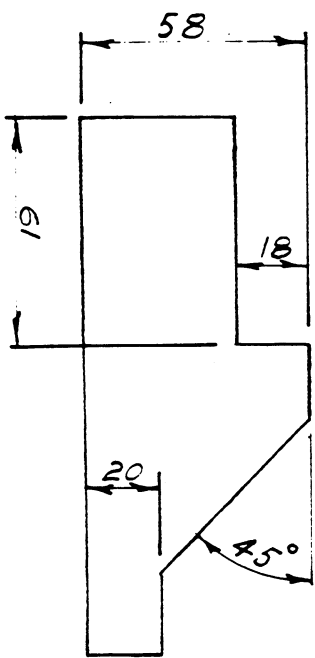

A _____
 B _____
 C _____
 D _____
 E _____
 F _____
 G _____
 H _____
 J _____
 K _____

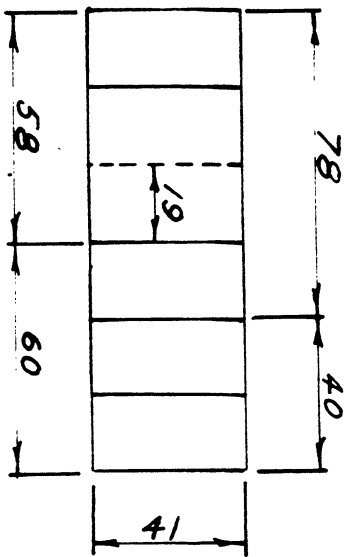
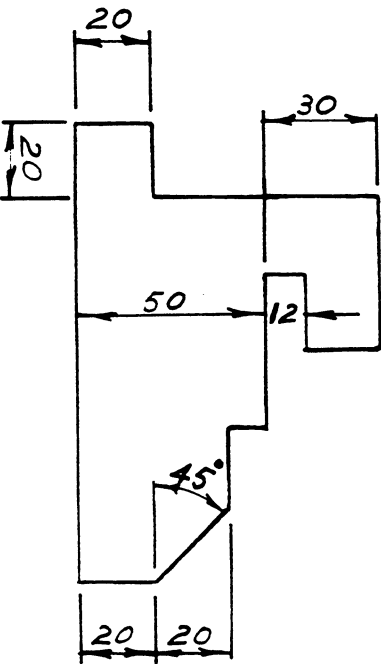
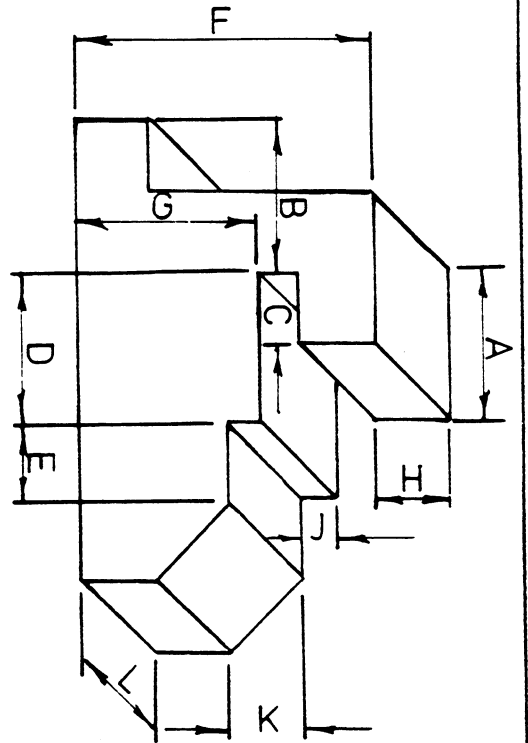

A _____
 B _____
 C _____
 D _____
 E _____
 F _____
 G _____
 H _____
 J _____
 K _____
 L _____

NOTE DRAWINGS NOT TO SCALE

COUNT THE NUMBER OF CUBES IN EACH STACK. ASSUME THAT THE BLOCKS ARE RESTING ON OTHERS WHEN MORE THAN ONE LAYER IS INVOLVED.

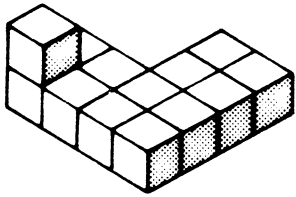

a

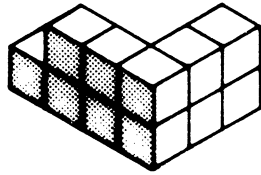

b

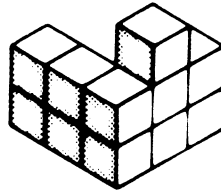

c

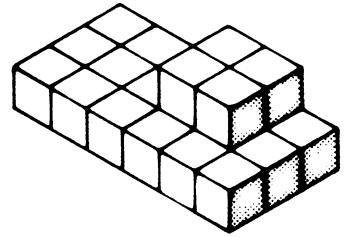

d

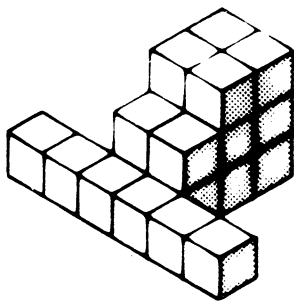

e

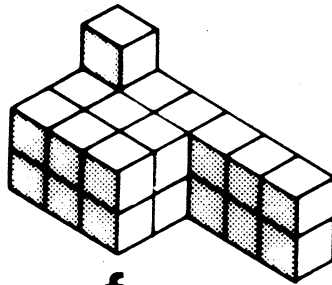

f

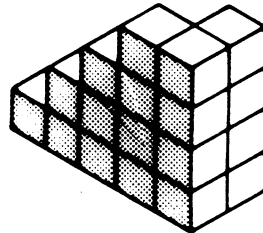

g

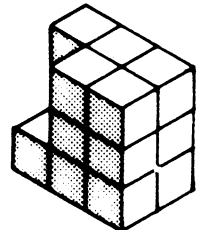

h

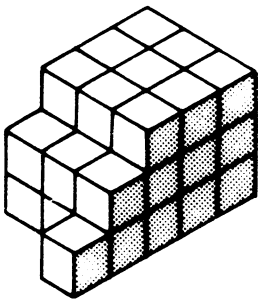

i

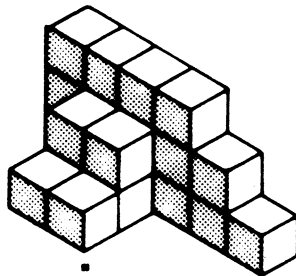

j

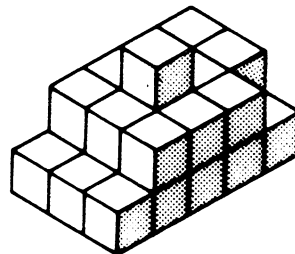

k

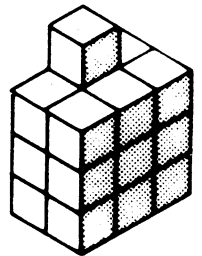

l

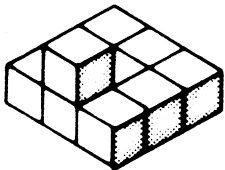

m

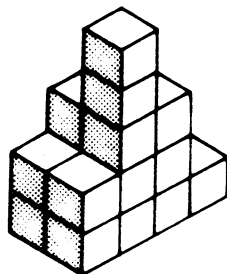

n

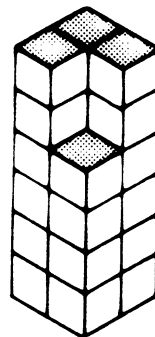

o

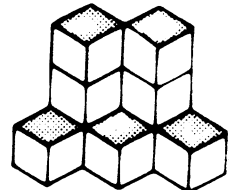

p

SHADING TECHNIQUES OR RENDERING OF THE SURFACES OF A PICTORIAL DRAWING GIVE IT GREATER EYE APPEAL. ASSUME THE LIGHT SOURCE IS COMING OVER THE OBSERVERS LEFT SHOULDER.

RENDERING

SOME SURFACE AND RENDERING TECHNIQUES ARE:-

1. LINE SHADING.
2. STIPPLING.
3. TONE SHADINGS.
4. COLOUR RENDERING.

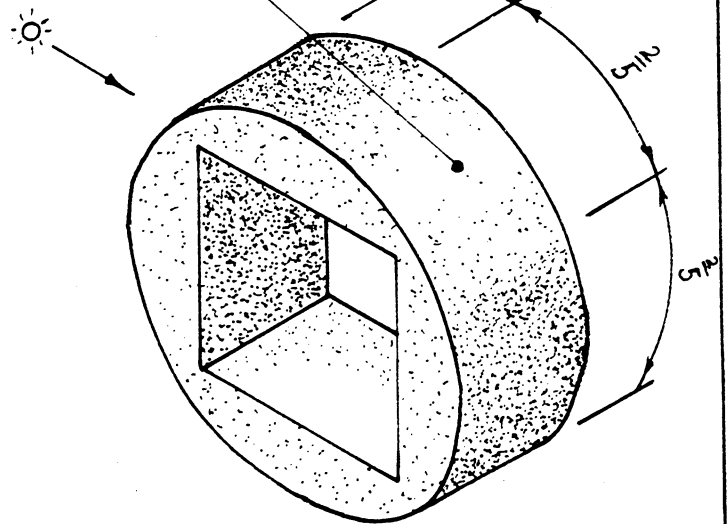
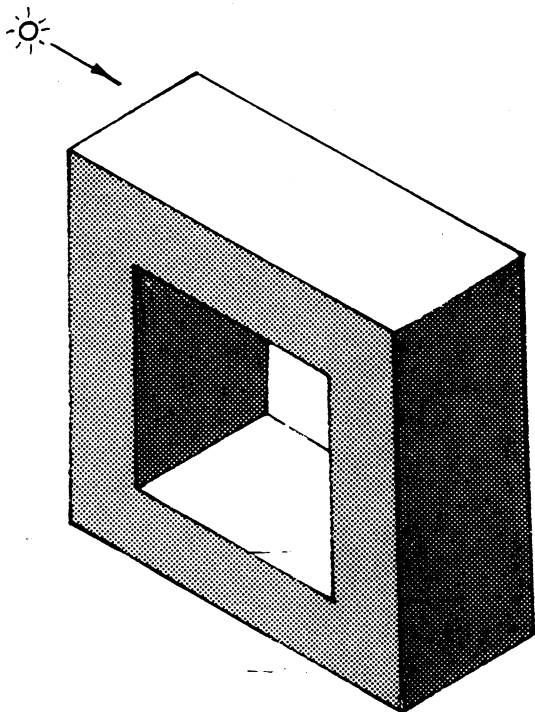
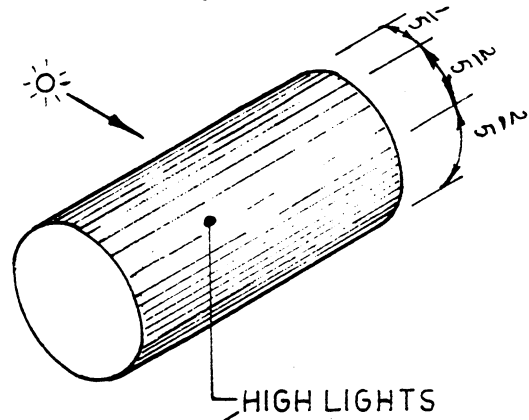
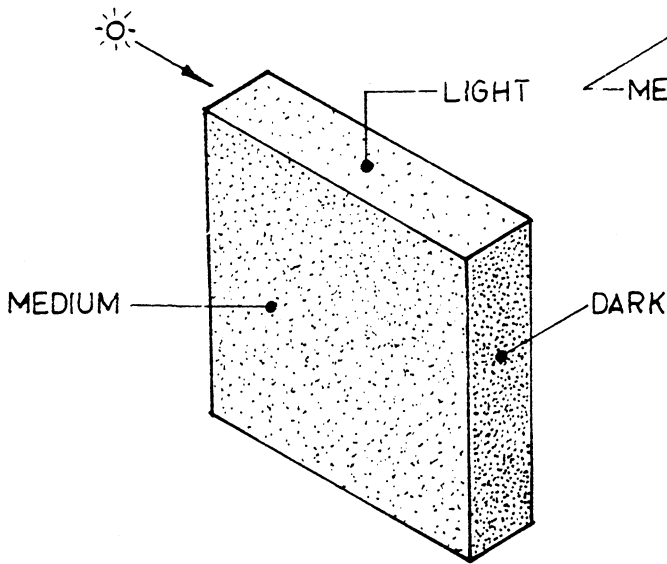
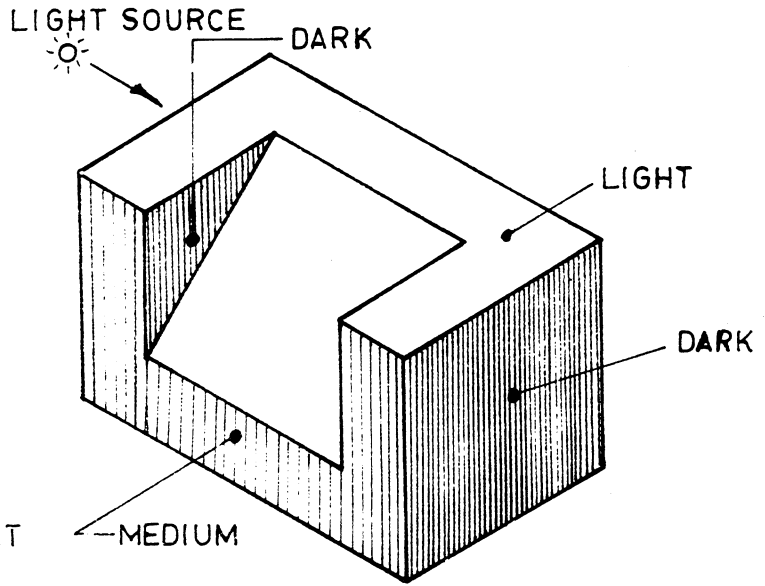

DRAWN

DATE