

Table of Contents

HEALTH EDUCATION

Theme: Germs & Disease

Lesson #1 – Where Germs Live	5
Ted E Bear Puppet	6–7
Virus & Bacteria Activity Sheet	8
Lesson #2 – How Germs Travel	9
How Germs Travel – Colour the Germs	10
Cover Your Sneeze!	11
Lesson #3 – Handwashing	12
Six Steps of Handwashing	13–14
Lesson #4 – Ways to Become Well	15
Ted E Bear Gets Sick Booklet	15–17

Theme: Medicines

Lesson #1 – Medicines Can Be Harmful	18
Lesson #2 – Only a Trusted Adult Can Give Medicines	18
Do Not Taste Anything Activity Sheet	19

Theme: Nutrition

Lesson #1 – Food Pyramid	20
Lesson #2 – Healthy Snacks	20
Food Patterns	21–23
Food Pyramid	24
Ted E Bear Goes Shopping!	25
Lesson #3 – Eating a Healthy Breakfast	26
Lesson #4 – Trying New Foods	26

Theme: Rest & Exercise

Lesson #1 – The Importance of Rest	27
Lesson #2 – The Importance of Exercise	27
Rest is Good for Me!	28
Exercise is Fun Bulletin Board Caption	29

Theme: Dental Health

Lesson #1 – Keeping Teeth Healthy	30
Connect the Dots – Cleanliness	31
Dental Health Secret Code	32

SAFETY

Theme: Fire Safety

Lesson #1 – Matches	33
Lesson #2 – Stay Away from Hot Things	33
Connect the Dots – Never Play with Matches	34
The Friendly Firefighter Puppet	35–36
Lesson #3 – Stop, Drop, Roll	37
Lesson #4 – Smoke is also Dangerous	37
Flame Pattern	38
Drop and Go Under the Smoke	39

Theme: Pedestrian Safety

Lesson #1 – Crossing the Street.....	40
Traffic Light Colour Words.....	41
Lesson #2 – Car Safety	42
Watch Out For Cars Safety Booklet	43–45

Theme: Electricity

Lesson #1 – Electrical Safety	46
Ted E Bear Learns About Being Safe Around Electricity.....	46–48

Theme: Guns

Lesson #1 – Preventing Accidents	49
Gun Safety Poster.....	50

PROTECTIVE BEHAVIOURS**Theme: My Body**

Lesson #1 – Learning to Name Body Parts	51
Lesson #2 – My Body is Special and Private.....	51
Can You Name My Body Parts? (Girl)	52
Can You Name My Body Parts? (Boy).....	53
Lesson #3 – Distinguish Between Different Body Parts	54
My Body Book	55

Theme: Feelings

Lesson #1 – Naming Feelings.....	56
Feeling Cards	57
My Feelings	58
My Big Book of Feelings	59–61
Lesson #2 – Safe Feelings	62
‘Me’ Puppet for Girls.....	63–64
‘Me’ Puppet for Boys.....	65–66

Theme: Touches

Lesson #1 – Good Touches & Bad Touches.....	67
What Would You Do If...?.....	68
The Touching Book	69–73
Bear Safe Bear Paw.....	74

Theme: Help From 000

Lesson #1 – You Can Call for Help.....	75
My Phone Book.....	76
Dial 000 Booklet.....	77

Theme: Strangers

Lesson #1 – Do Not Talk To Strangers	78
I Do Not Talk To Strangers Award	78
Lesson #2 – Use of Enticement	79
The Stranger Safety Award	80

Where Germs Live

Objectives

Students will understand that there are different types of germs that can be found in different places. These germs can live inside and outside the body.

Lesson

Begin the lesson by introducing Ted E Bear. You will find the patterns to make the Ted E Bear puppet on pages 6–7. You need to prepare the Ted E Bear puppet before teaching the lesson. Later in the lesson the children will be able to make their own puppets to take home.

Special Note: Ted E Bear is used throughout the curriculum. You may wish to use a stuffed animal bear instead of the puppet.

Use the Ted E Bear puppet to guide a classroom discussion about what it feels like when you are sick. Encourage the children to discuss any illnesses they have experienced. Ask the children if they know anyone who is sick. Guide the

discussion to include the word ‘germ’. ‘Does anyone know what a germ looks like? Did you know that germs can make you sick? Germs are so small that people cannot see them.’

Show the children the *Virus and Bacteria* Activity Sheet found on page 8. Explain that both of these germs can make children sick. Provide a copy of the *Virus and Bacteria* Activity Sheet for the children to colour.

When the children have finished colouring the page, ask them where they think germs are found. Brainstorm and write down all the childrens’ ideas. Explain to the children that germs are found in the air, on food, on doorknobs – germs are found everywhere. Germs can live outside the body and some germs can live inside a body.

When you have finished the lesson, let the children make their own Ted E Bear puppet.

Teacher Notes

Ted E Bear Puppet

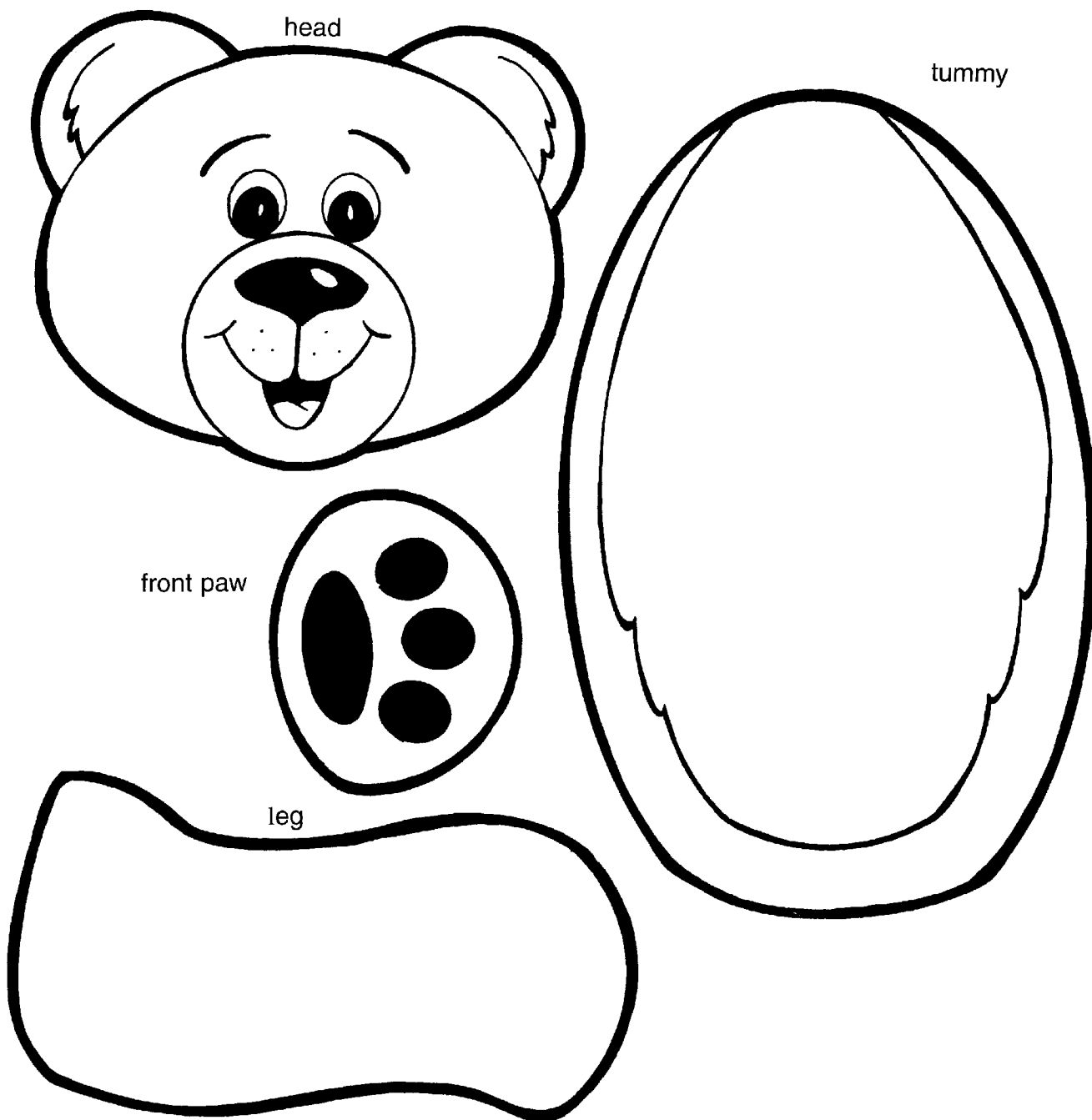

Directions:

Copy the head, legs, paws, arms and stomach for each child. Let the children colour and cut out the pieces. Glue to a paper bag.

Medicines Can Be Harmful

Objectives

Students will distinguish between helpful and harmful ways to use medicines. Students will learn that medicines can be dangerous if used improperly.

Lesson

Collect empty prescription bottles and over-the-counter medication containers. Get samples of warning stickers used on prescriptions. Contact

your local Poison Information Centre and ask for 'warning' stickers.

Explain that medicines come in different shapes and sizes. Some medicines even look and taste like lollies.

Children are not able to tell the difference. Only adults can tell the difference between medicine and lollies.

A child should **NEVER** taste or put anything into her or his mouth

without knowing what it is. Only take medicines given by a trusted adult!

Have the children cut out pictures of medicines from magazines. Have them glue them onto a piece of construction paper.

Discuss people who may give medicines to a child: parents, nurse, doctor, or a trusted adult such as a grandparent, aunt or uncle.

Only a Trusted Adult Can Give Medicines

Objectives

Students will learn that one should never eat or drink anything unless she or he knows what it is.

Lesson

Tell the students that there are many things that look good and smell good, although some of these things could be very dangerous. Always ask an adult before tasting anything! Provide the children with the *Do Not Taste Anything* activity

sheet found on page 19.

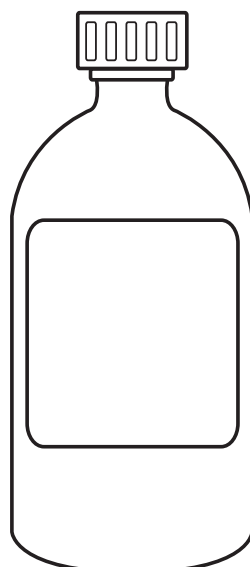

Teacher Notes

Do Not Taste Anything

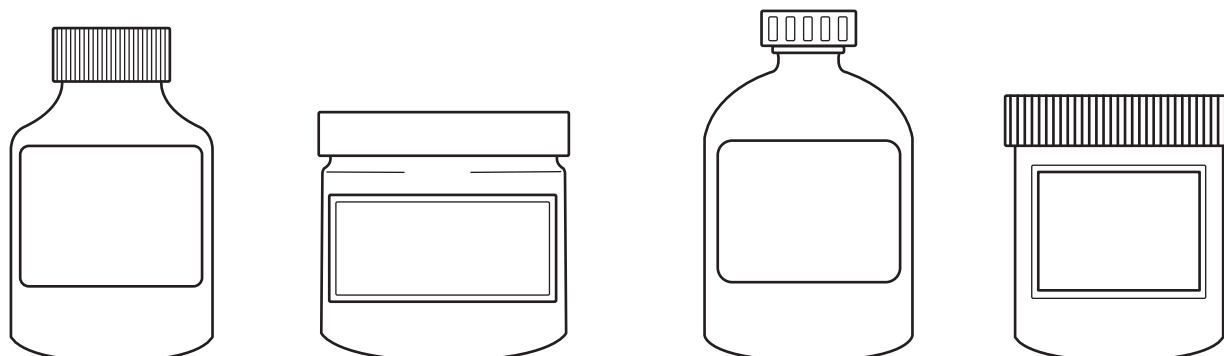
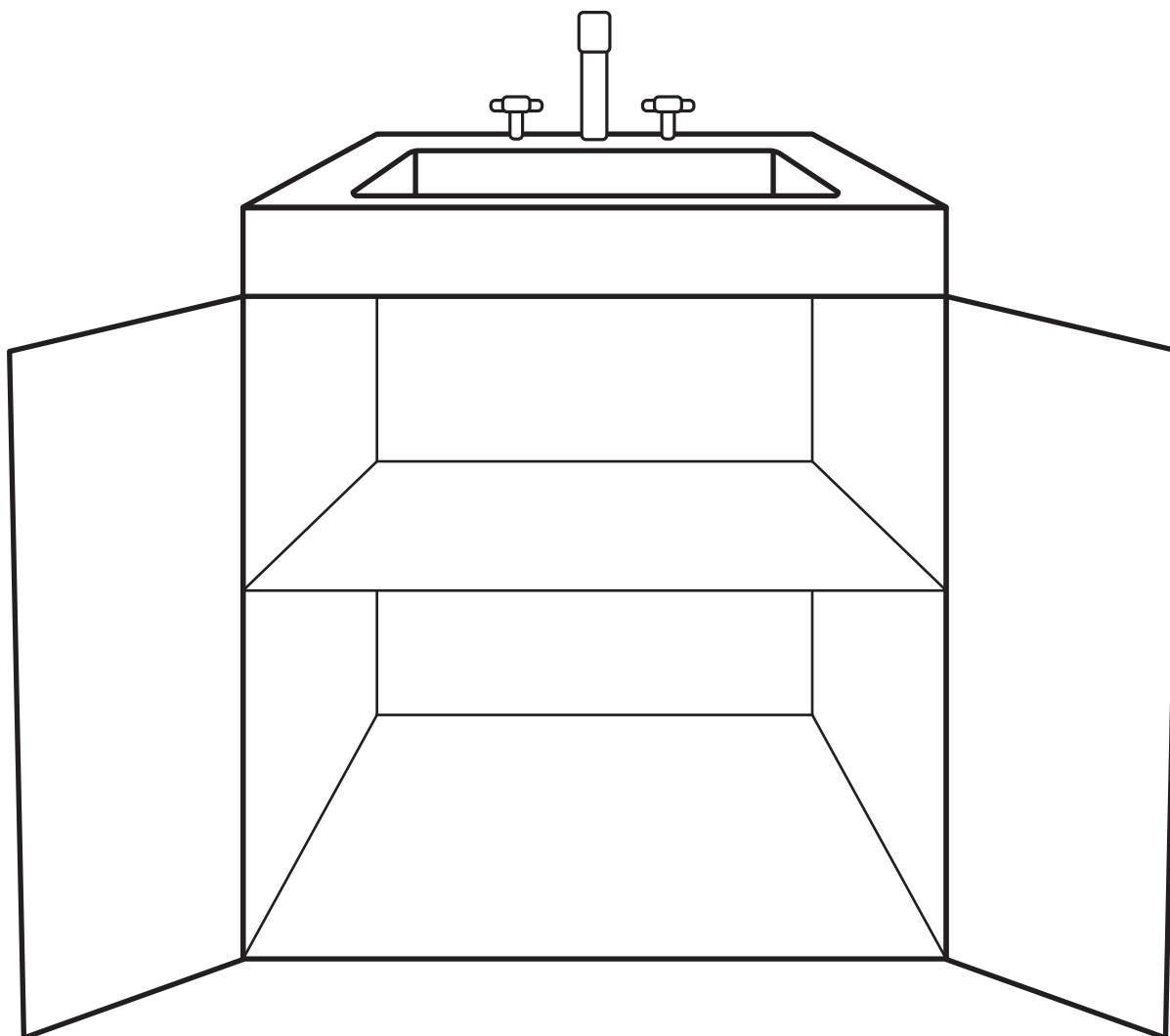

Directions: Cut out the bottles and glue them under the sink. Draw or stick warning stickers on each of the bottles.